



INSTRUCTIONAL MANUAL

VW piezometer

[Model 1510, 1520, 1530, 1540, 1545, 1515, 1560, 1500S, 1500US]

INSTRUMENT

ACE

Geotechnical & Structural Instrumentations

Civil Engineering

Bridge
Structure
Dam
Tunnel
Railway
Roadway
Marine Structure
Foundation
Pile
Mine
Landfill
Slope
Excavation

Thank you very much for purchasing Ace Instrument products.

All ACE Instruments products are manufactured and calibrated according to the manufacturing standard and ISO-9001 quality assurance system. Please pay attention to the handling and read the manual carefully before use for proper data collection and analysis. Please observe the installation regulations. This product must be installed, operated and interpreted by a qualified technician. Content and specifications are subject to change without notice. Copyrights belong to Ace Instrument and unauthorized copying is strictly prohibited without our permission.

Please feel free to contact us if you have any questions or inquiries about geotechnical measuring instruments.

It is the product of Ace instrument which manufactures the first value in geotechnical & structural instrumentation.

These products are the crystals of sweat that was created by the continuous research and development of our engineers. we are trusted as a partner of civil engineering / building / rock and geology experts in overseas and are loved by the domestic industry through customer impressions.

Limited Warranty

- 1. ACE INSTRUMENT CO., LTD. holds the full responsibility of our products regardless of purchasing places and how you get it. The product passed a rigorous test and was under the quality management by top engineers.**
- 2. If any defects of manufacturing are found or any breakdown happens within 3 years from purchasing date, we guarantee repair, adjustment and verification at no cost. But, when you ask repair, adjustment and verification, ACE INSTRUMENT CO., LTD. is not responsible for shipping and handling fees. In case the quality warrantee date has expired, or any breakdown owing to carelessness has happened and other operations such as dealing with zero point are needed, services would be provided at a minimum cost.**
- 3. But, in the case the purpose of use is changed, incorrect installation, the use of components for manufacturing and installation, and repair of other firms take place, ACE INSTRUMENT CO., LTD is not liable to Quality warrantee.**
- 4. In case of a product defect in manufacturing during the warranty period, the product will be replaced.**
- 5. In case of failure or defect in the normal use of the user during the warranty period, repair, calibration and replacement of parts will be free of charge.**
- 6. In case of failure or defect caused by negligence of the user during the warranty period, repair, calibration and replacement of parts will be charged.**



ACE INSTRUMENT CO., LTD.

The first value in Geotechnical
& Structural Instrumentation

Tel : +82 - 31 - 459 - 8753 ~ 7
Fax : +82 - 31 - 459 - 8758
Homepage : www.aceinstrument.com
E-mail : acens@naver.com

1. Introduction	2
1-1 Introduction	2
1-2 Application	3
1-3 Specification	6
2. Installation	7
2-1 Prior to installation	7
2-2 Installation	7
2-3 Installation in borehole	8
2-4 Installation in embankment	9
2-5 Installation in dam	9
2-6 Push-in type installation	10
2-7 Use as water level meter	11
2-8 Use as tide water level meter	12
2-9 Regard with falling of thunderbolt	13
2-10 After installation	14
3. Readout unit & datalogger	15
3-1 Compatibility of readout unit	15
3-2 Kinds of readout unit	15
4. Connection & use	16
4-1 Connecting sensors with readout unit	16
4-2 Connecting sensors with universal terminal box	16
4-3 Reading with readouts	16
4-4 Reading with VW minilogger	17
4-5 Reading with wireless data accusation system	17
5. Data reduction	18
6. Trouble shooting	19
7. Keep/care & reform/service	20
7-1 Keep/care	20
7-2 Reform/service	20
8. Simple calibration method for precision and accuracy	21
9. Geotechnical Instruments Installation and Operation Tips	22

1-1 Introduction

VW piezometers convert water pressure on the diaphragm to be measured into an equivalent frequency signal. The pressure on the diaphragm changed by fluid pressure causes a change in tension of the wire.

The wire excited by the plucking vibrates at its resonant frequency. The frequency signal transmitted through a cable to the readout.

Special stainless steel is used to minimize thermal zero shift in the frequency and the precision of the diaphragm is high when manufactured it.

Also the pressure transducer is equipped with a lightning protection for protecting the sensor electrical shock and a temperature device for compensating for temperature variations.



Dimensions(mm)

Model	1510	1515	1520	1530	1540	1545	1500S	1500US
OD	Φ19.8	Φ26	Φ32	Φ25.4	Φ25.4	Φ25.4	Φ17.5	Φ12.7
L	169.5	169.5	185	151	169.5	219	169.5	151

1-2 Applications

The VW piezometers are designed to measure pore water and fluid pressure at the pressure tank and pipe line, borehole, foundation, and dam.

- Measurement of the effects of drainage systems used for excavations.
- Measurement of pore water pressure to determine safety factor under excavation or banking.
- Measurement of water level to check the performance in rivers, reservoirs, standpipes.
- Measurement of pore water pressure to determine slope stability.
- Measurement of flows of underground water and water leakage in embankments, dams and artificial lakes.

Model 1510 [standard]

Model 1510 VW piezometer is designed to be embedded in earth fills and at concrete interfaces or inserted into boreholes and small diameter pipes.



Model 1520 [push-in type]

Model 1520 VW piezometer is placed in consolidated fine grain materials such as sand, silt, or clay.

The external housing is a thick walled cylinder fitted with a tapered shoe at one end, and an EW drill rod or standard pipe thread adapter at the cable entry end. It can withdraw to use again after construction.



Model 1530 [pressure sensor type]

Model 1530 VW piezometer is designed to measure fluid pressure in pipelines for industrial and hydraulic.

Model 1530 was processed as 3/8" pipe thread, so you can directly unite to the female thread part or you can unite to the male thread part using the union. And it is useful to measure up stream pressure in a hydroelectric power plant.



Model 1540 [heavy duty type]

This model is specially manufactured to use in the site where semi-permanent measurement is necessary like dam site. PE sheath cable with stainless wire rope and diameter of $\phi 7$ is adapted.



Model 1545 [ring filter type]

This model is equipped with a ring type large metal filter. The ring type filter has a very wide contact surface and can be used for all part such as seawater, sand layer, sediment layer, mineral layer. It can use as water level sensor as well.



Model 1515 [low pressure type]

This model is designed to measure low pressure. There are three varieties of measuring range as 1.0/1.5/2.0kg/cm² for measuring water pressure.



Model 1500S [slim type]

This model is made into small size (OD $\phi 17.5$ mm) for measuring at ID $\phi 19$ mm standpipe.



Model 1500US [ultra slim type]

This model is made into small size (OD ϕ 12.7mm).



1-3 Specification

Model	1510 (STD)	1520 (Push-in)	1530 (Pressure)	1540 (Heavy duty)	1545 (Ring filter)	1500S (Slim size)	1500US (Ultra slim)	1515 (Low pressure)	
Sensor element	Vibrating wire sensor								
Range	3.5~70 kg/cm ²						3.5, 7kg/cm ²	1.0, 1.5, 2.0 kg/cm ²	
Resolution	0.025% FSR								
Accuracy	±0.1% FSR								
Nonlinearity	±0.5% FSR								
Over range capacity	150% FSR								
Thermal zero shift	Less than 0.05% FSR / °C								
Operating temperature	-40 ~ 80 °C								
Built-in temperature device	Thermistor (3kΩ)								
Temperature device range	-40 ~ 105 °C								
Temperature device accuracy	±0.5 °C								
Waterproof	1000m H ₂ O								
Materials	Stainless steel, high grade epoxy resin potting								
Filter	Standard : 50 micron sintered stainless filter / air transit pressure : about 5.6kg/cm ² Optional : 1 micron / 100 micron ceramic filter								
Weight	0.2kg	0.8 kg	0.3 kg	0.3 kg	0.5kg	0.2 kg	0.1kg	0.3kg	
Signal cable	Ø6.4 mm, 0.37mm ² ×4C shielded PU sheath cable (For 1540 : Ø7mm, 0.34mm ² ×4C Aramid fiber reinforced PU sheath cable)								
(Note)	<p>The accuracy depends on air entry in the filter, compensating thermal zero shift and difference in air pressure Upon request, it can be manufactured from STS316, anti-corrosion material that can be used in seawater environment. There may be a negative pressure zon in civil engineering sites. Our company is equipped with negative pressure calibration facility and will make a second calibration by -1kg/ cm² if requested.</p>								

2-1 Prior to installation

The VW piezometer is very sensitive instrument. If it is dropped or get an excessive shock during transporting a sensor can be got a damage which cause a malfunction or increase error.

If sensor's calibration temperature and workable temperature are too different, keep in workable temperature at least 3 hours.
It is able to clearly compare the initial value and current measured value before installation.

When not in use or before installation it must be removed water from sensor. Drenched in water, frozen or water-filled piezometer can be lost function. When removing the water hold filter as face-down. The water will be escaped naturally.

Before installing the VW multi point piezometer, please compare the value of calibration sheet with a value (no load state) by connecting a VW readout unit. Also, it may vary between atmospheric pressure of calibration and atmospheric pressure at the installation site. By measuring the atmospheric pressure, it must have corrected the data conversion. The atmospheric pressure is changed at a rate of **$10.215 \times 10^{-3} \text{mHzO per 1.0mbar}$** .
The calibration sheet of VW multi point piezometer must be kept well always.
If you believe that the measured value is something wrong, check out the relationship between the frequency of sensor output and pressure by applying ABS Factor or sensitivity of calibration sheet.

Caution

Please be careful not to lose the calibration certificate because it must have the calibration certificate to convert measured values into engineering units.

2-2 Installation

General information

When installing the VW piezometer, be sure to thoroughly review the installation location, signal cable connection method, and surrounding conditions before installation. Be sure to check for sensors and installation accessories before installing them, otherwise prepare them.

No load measurement value stable

- ① The VW piezometer is very sensitive to changes in atmospheric pressure. Therefore, to accurately measure the pressure, use a barometer to calibrate the head height by the pressure difference in places where there are many changes in pressure such as dams, valleys, and reclaimed land.
- ② The VW piezometer is equipped with a 50 μm low-density filter, so it should be installed after removing the air in the water for about 12 hours before installation to obtain the correct measurement value.
- ③ When installing the VW piezometer, insert a signal cable 10 ~ 20% more than the depth of borehole to prevent cable breakage due to settlement.
- ④ Unsaturated Toner Pore In areas where water pressure exists, it is recommended to use a 1 μm ceramic filter.
- ⑤ When installing the VW piezometer on soft ground, if the signal cable is not protected by a garden hose or the like, if the signal cable is broken due to the rotation of the drill core, or if the cable sheath is peeled off, a short circuit occurs.
Be sure to protect the signal cable with a garden hose when installing.
If this construction method is not convenient, choose a Model 1540 VW piezometer designed for heavy duty use.

2-3 Installation in Borehole (Model 1510, 1500S, 1500US, 1540, 1545)

- Tip preparation
- ① Fill water in the bucket.
 - ② Dip the VW piezometer into the water with the tip facing downwards.
 - ③ After 5 minutes, hold the VW piezometer and gently tap on the top of the VW piezometer located on the top of the water bottle to flow air out through the filter.
- Installation
- ① Clean the floor of the borehole where the VW piezometer is to be installed so that there is no clay or impurities.
 - ② Insert sand to the position where the VW piezometer is installed.
 - ③ Measure the depth of the borehole where the VW piezometer will be installed and mark it with tape on the cable.
 - ④ Put the VW piezometer into the sand bag, fill the inside with sand, and tighten the sand bag entrance tightly.
 - ⑤ Put the VW piezometer in the sandbag into the borehole and carefully place it on the cable until the position indicated on the cable matches the top of the borehole.
 - ⑥ Fill the filter sand with at least 150mm to cover the VW piezometer.
 - ⑦ Fill the top of the VW piezometer with at least 50 cm of sand or sand gravel.
 - ⑧ Pour the bentonite into the borehole about 30cm and grout the top of the measuring hole.
 - ⑨ Wait for enough time until the inside of the VW piezometer becomes equal to the water temperature, connect the jumper cable of the VW readout unit to the signal cable of the VW piezometer, and record the measured value displayed.

Caution

In case of Model 1560 VW vented piezometer, after installing the sensor, the end of the cable should be attached to the vented case and the desiccant (silica gel) should be placed inside the case.

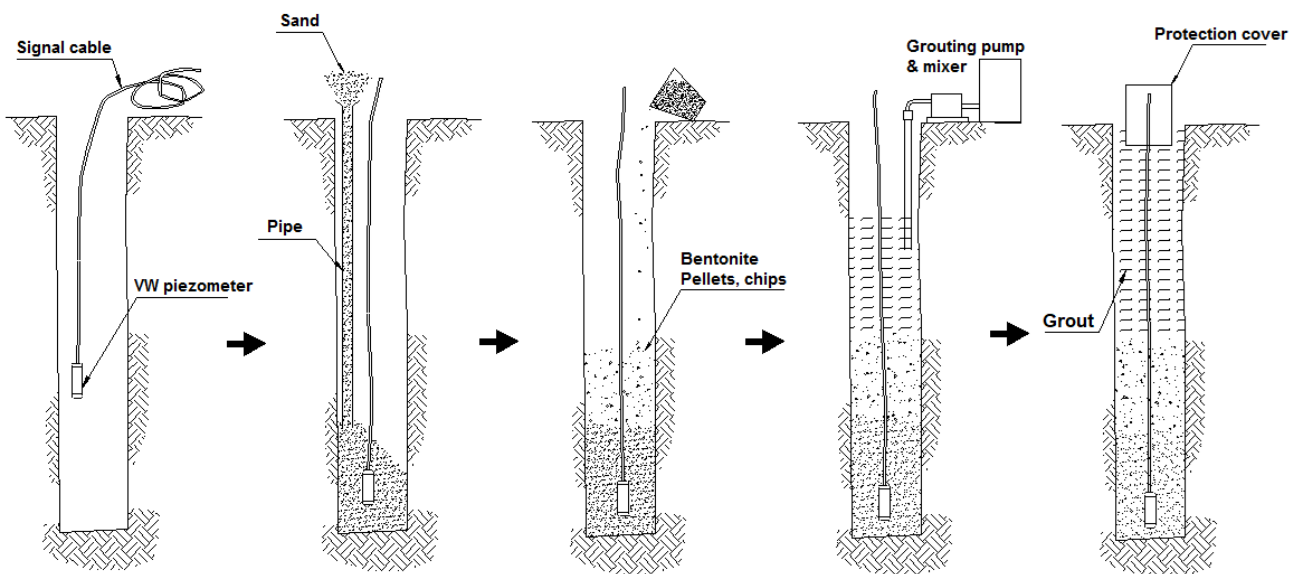

[Installation of VW piezometer in borehole]

Grout mixing ratio

Division	Hard & Medium Soil		Soft Soil	
	Weight	Weight ratio	Weight	Weight ratio
Portland cement	10kg	1	10kg	1
Bentonite	3kg	0.3	4kg	0.4
Water	25kg	2.5	66kg	6.6

2-4 Installation in the embankment (Model 1510)

- | | |
|-----------------|--|
| Tip preparation | <ol style="list-style-type: none"> ① Fill water in the bucket. ② Dip the VW piezometer into the water with the tip facing downwards. ③ After 5 minutes, hold the VW piezometer and gently tap on the top of the VW piezometer located on the top of the water bottle to flow air out through the filter. |
| Installation | <ol style="list-style-type: none"> ① Dig a 600 × 400 × 200mm trench in the embankment layer where the VW piezometer is to be installed. ② Put the wet sand on the trench. ③ With the filter facing upwards, tilt and then fix the VW piezometer about 45°. ④ Cover the sand with VW piezometer and cover with dirt. ⑤ Wait for enough time until the inside of the VW piezometer becomes equal to the water temperature, connect the jumper cable of the VW readout unit to the signal cable of the VW piezometer, and record the measured value displayed. |

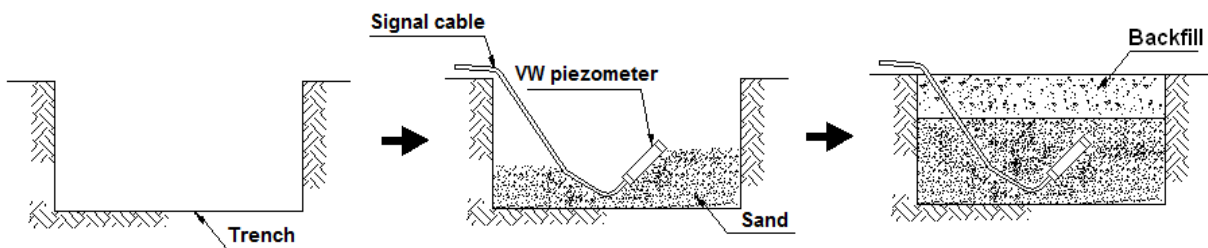

[Installation of piezometer in the embankment layer]

2-5 Installation in Dam

When installing a VW piezometer in a dam, water purification plant, reservoir, etc., and measuring the water level, the sensor should not be installed without auxiliary equipment in the water but installed in a plastic pipe.

This is because when the waves hit, convection occurs in the water and the water becomes dynamic, so that the output value may not stabilize and fine movement may occur.

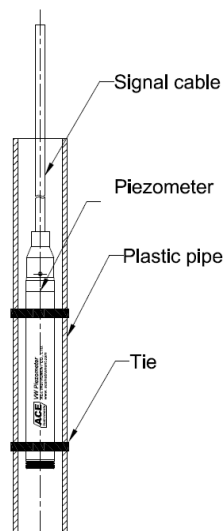

2-6 Push-in type Installation (Model 1520)

Soaking filter	<p>This installation method is used when installing a Model 1520 VW piezometer. It should only be installed on deposited soil or soft mud.</p> <ol style="list-style-type: none"> ① Turn the tip with the filter counterclockwise to remove the filter from the VW piezometer. Prepare the distilled water and put the filter (tip part) in the water for 24 hours. ② Dip the tip part and the VW piezometer into the cold water without air. Reassemble the tip part and VW piezometer in the water, and gently pat the VW piezometer to remove the influent air. ③ For safe transport, the VW piezometer should be fixed in a bag filled with water. Seal around the signal cable and seal the top of the bag with tape.
Installation	<ol style="list-style-type: none"> ① Prepare a stick for installation. You must temporarily attach the tape to the stick or scale marks on the stick. ② Drill holes until water comes out or mud comes out. ③ Connect the signal cable to the VW Readout Unit and check that the measured value can be read by pushing the VW piezometer. ④ Fix the VW piezometer to the push stick. Lower the VW piezometer an appropriate depth. Use additional stick if necessary to prevent the underside of the stick from turning. If the VW piezometer is to be pushed, the pressure should not exceed the measurement range stated in the calibration report. In this case, check the measured value from time to time. When pushing a VW piezometer into an impermeable material, you can omit the 'dipping filter'. ⑤ If the VW piezometer is located below the perforation, remove the stick that has been pushed by the pipe rotation in the clockwise direction. (There is a left screw on the mounting part.) Push the adapter from the bottom of the stick and make sure it is fully buried. ⑥ Pour the bentonite into the measuring hole about 30cm and grout the upper part of the measuring hole with cement. ⑦ Wait for enough time until the inside of the piezometer is equal to the ambient temperature and record the measurement value displayed after connecting the jumper cable of the VW readout unit to the signal cable of the VW piezometer.

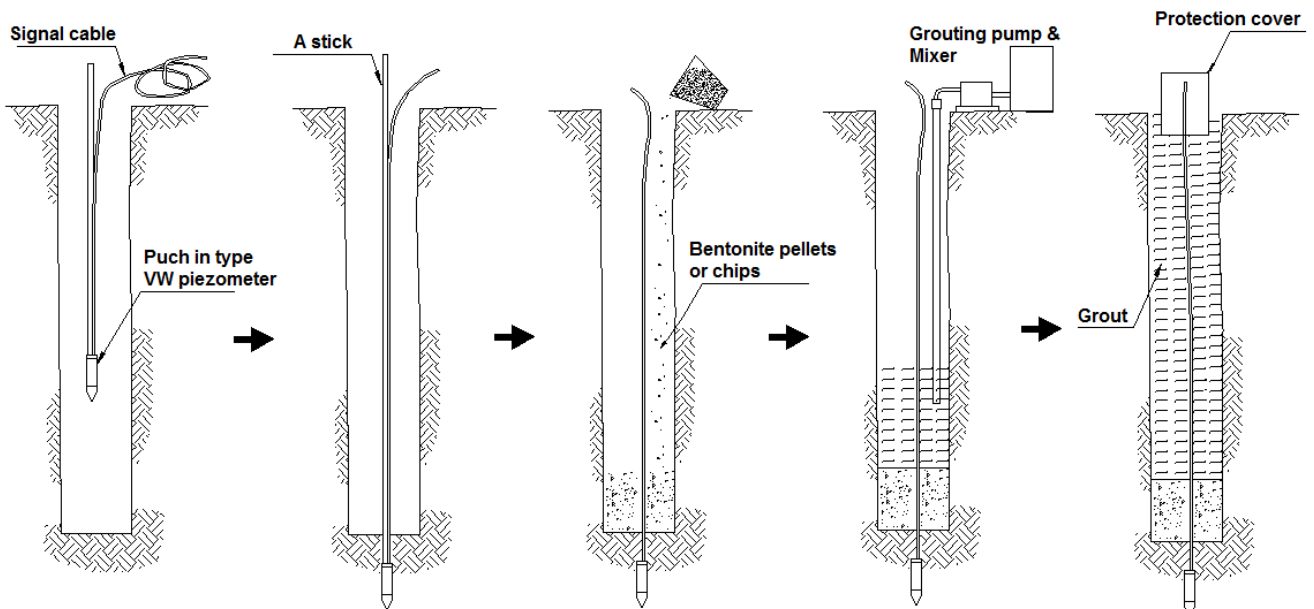

[Installation of push in type VW piezometer]

2-7 Use as water level meter

- VW piezometer can measure automatic groundwater level using automatic measurement system.
Measuring the pressure of the water level from the position where the VW piezometer is installed, it is converted by the meter unit and the installation method is as follows.
- Tip preparation
- ① Fill water in the bucket.
 - ② Dip the VW piezometer into the water with the tip facing downwards.
 - ③ After 5 minutes, hold the VW piezometer and gently tap on the top of the VW piezometer located on the top of the water bottle to flow air out through the filter.
- Installation
- ④ Measure the current water level by manual VW piezometer.
 - ⑤ Insert the VW piezometer into the installed groundwater measurement pipe.
After inserting the signal cable at a depth within 5 ~ 15m of the current level measured in ④, fasten the signal cable to the pipe or fixing pin so that it does not come out into the pipe.
 - ⑥ Wait for enough time until the inside of the VW piezometer becomes the same as the ambient temperature, connect the jumper cable of the VW piezometer to the signal cable of the VW piezometer, and record the measured value displayed.

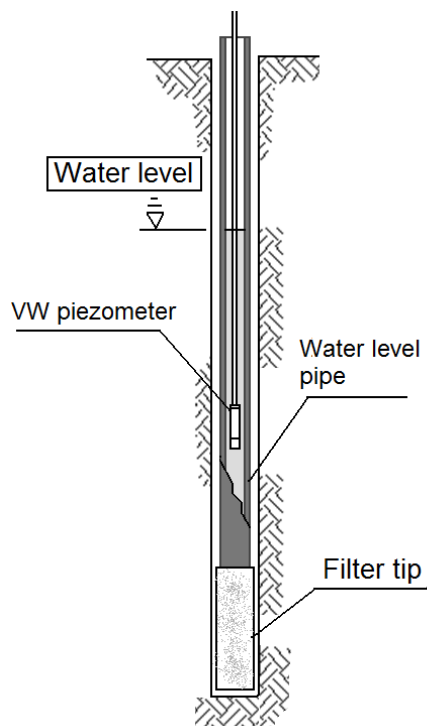

[Installation it as water level meter]

2-8 Use as tide water level meter

There is a case where a VW piezometer installed on the coast or in the harbor, which may measure the water level during the ebb and flow of the tide.

- ① Cut $\Phi 60\text{mm} \sim \Phi 70\text{mm}$ perforated pipe as about 1 m and close the either end with cap.
- ② Fill up a pipe with fine sand and insert VW piezometer in the sand. And close either end with cap. (Be careful not to damage or not to cut.)
- ③ Cover tube for protecting cable at the signal cable.
- ④ Drill at the wall that is a lower situation than you expect minimum water level and fix the pipe that have the VW piezometer with anchor bolt using U type bolt.
(In case that the pipe is already filled with water, fix anchor bolt at the point that you can install extending the pipe.)

Fully wait until the inside of piezometer is same with surrounding temperature. And connect the jumper cable of VW readout unit to the signal cable of VW piezometer. And record the measure value.

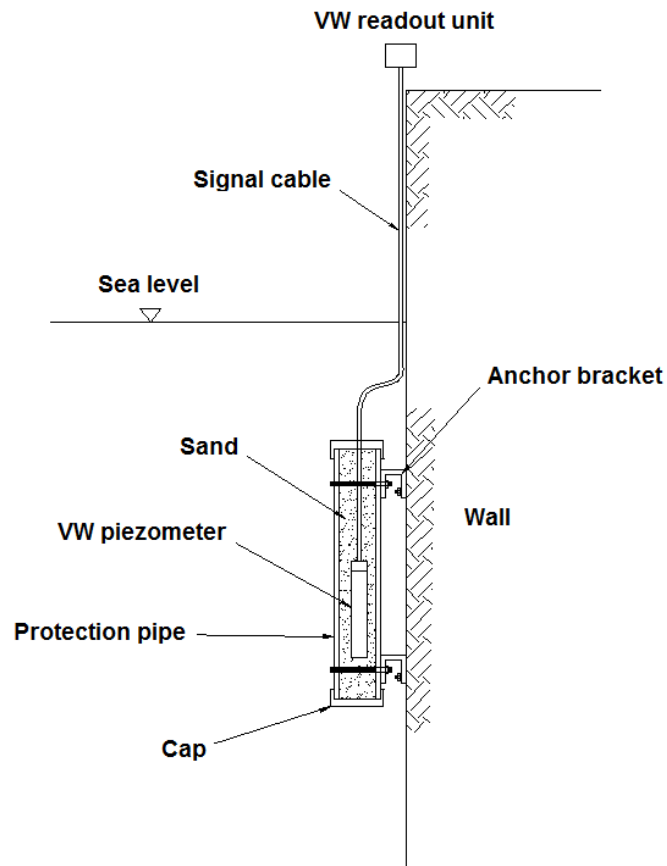

[Installation it as water level meter]

2-9 Regard with falling of thunderbolt

The measuring devices and sensors are normally installed on the broad area such like soft-ground and dam that the water flows.

Inside of the sensors, there is the small Surge Arrester to protect the sensor from over-voltage. This small Arrester can protect the sensors from a small permissive electric flow due to accident of electricity leak.

When lightning comes with rain during the monsoon season in summer, the volume and strength of the thunderbolt (lighting) is much bigger than we can expect. Therefore sensors might not be operated in case the lightning hits the place nearby installation site for sensor.

In order to prevent such a this accident, for the site that the continuous measuring is required, the 2nd lightning conducting device must be connect to the end part of sensors, Shield cable from sensor should be connect to the ground as using lightning conductor(made of copper).

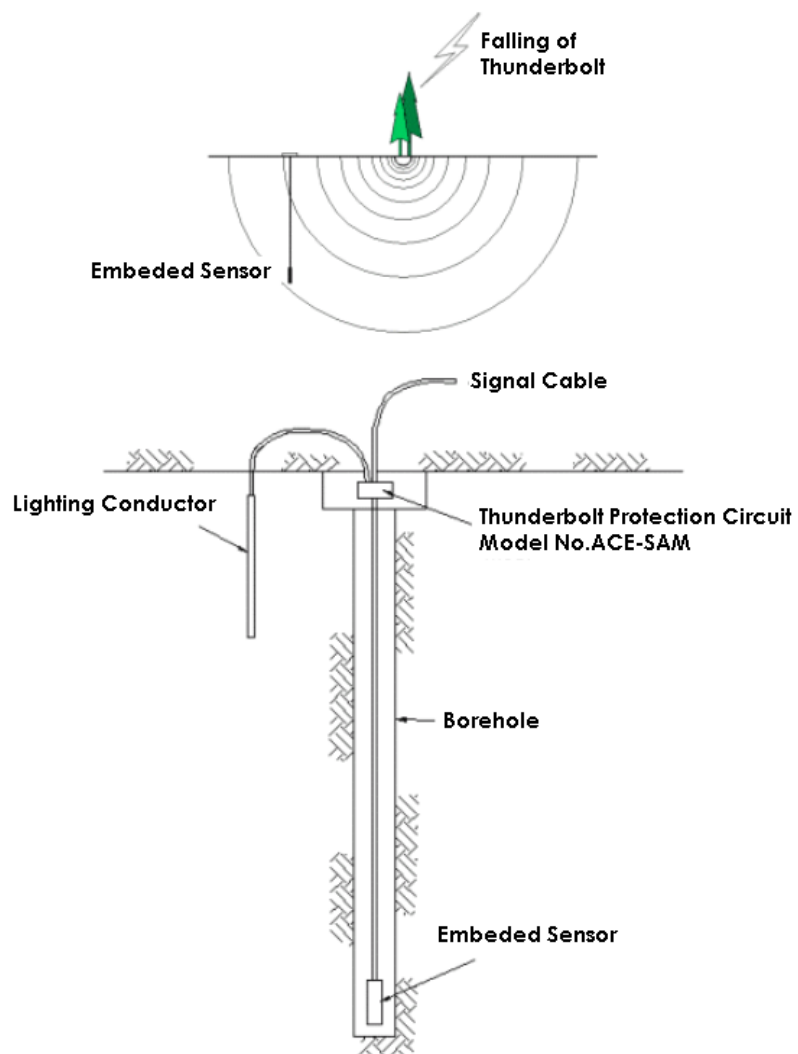

[Composition of thunderbolt protection circuit]

Thunderbolt protection circuit

If you need Surge Module (Model no. ACE-SAM) for protecting sensors from lighting. Please contact us so that we can provide you Surge Module.

If the continuous measuring is required and the measuring device is much importance in the site. This Surge Module should be installed with sensors.

2-10 After installation

Marking the cable	<ul style="list-style-type: none"> ■ Please mark the end of the signal cable by tagging or labeling to identify the installed sensors of VW weir monitoring system when measuring. ■ As Ace Instrument Co., Ltd. releases the products after marking with manufacturing numbers, you may easily identify the products. If not marked with manufacturing numbers, you need to mark it with additional means. When marking on the end of cable, please use the minimum space.
Protection of sensor	<p>After installing the VW piezometer, it should be protected from falling objects or direct external influences. This improves the durability of the sensor and enables accurate measurement.</p>
Protection of sensor	<p>Be careful not to get the cable damaged through the displacement generated by winding or bending. Bend the cable in two time's curvature for allowing the soft bending. The scale of bending must incorporate the unsupported length.</p> <p>Check if there is any clogging portion, sharp surface and tore portion near the VW weir monitoring system. If there is any dangerous portion, either eliminate it or make the bypass path of cable.</p>
How to connect cable	<ol style="list-style-type: none"> ① Prepare the high quality 4 core signal cable allowing the complete closing. ② Peel off the external covering of signal and the extension cables about 50mm, the end of lead wire about 10mm. ③ Make connection between the same colored lead wires, solder with outdoor soldering iron. ④ Insulate the cable given heating after cover wiring portion with wind the shrinkage tube of internal diameter about 3 mm. If there is not the shrinkage tube, wind the cable with insulating tape. ⑤ Wind the peeled off cable with insulating tape. ⑥ For the perfect waterproof connection, one time sealing kit made from epoxy resin must be used for the wiring portion.
Treatment of signal cable	<ol style="list-style-type: none"> ① When treating the cables, be careful. The cable is not to get damaged and should not be any obstacle for the passing of vehicle or men. ② For the protection of cable, use the protective tube to prevent the cable from being damaged or impacted by external impaction or equipment. ③ If you bend the cable too excessively or pull it too hard, the cable may be damaged or there may be any error in measured value. ④ Shield wire must ground. ⑤ Do not place the cable at the place where the cable may be pressed by heavy goods or near the chemical materials. ⑥ For the efficient measurement or clear treatment of signal cables, collectively place the cables by using the universal terminal box.
How to use sealing kit	<p>The sealing kit is a water-proof and insulating material for cable connection via epoxy when different kinds of signal cables are connected on site.</p> <ol style="list-style-type: none"> ① If the sealing kit is appropriately cured, this wiring method might enhance the electrical characteristic and cable strength. ② It is recommended that the sealing kit and wiring supplemental materials supplied by our company shall be used. ③ Please refer to the enclosed user's guide for using the sealing kit.

3-1 Compatibility of readout unit

There is a variety of indicators/readout units connecting vibrating wire sensor/VW sensor. All vibrating wire sensors of ACE INSTRUMENT CO., LTD are compatible with and connectable to all kinds of VW sensor Readout Unit or Data logger.

3-2 Kinds of readout unit

Readout Unit	<p>Readout unit or indicator means only reading and displaying the data sent by sensor. Indicator is shown with Hz, 10^3Hz^2, a few $\mu\epsilon$ and temperatures($^{\circ}\text{C}$). One indicator shows all these. Another one shows a few. ACE INSTRUMENT CO., LTD holds ACE-800 and next page covers connection method.</p> <p>In the case of products from other firms, connect the device after studying the brochures of Readout Unit and the sensor.</p>
Data Logger (Output device with data storage and transmission function)	<p>Data Logger is an output unit which reads and shows the data from sensors. It also can store the data and send it to a computer via RS-232 teleport. The measuring unit is the same with that of the Readout Unit.</p> <p>ACE INSTRUMENT CO., LTD holds ACE-1000 and ACE-1100 Mini Logger, next page covers connection method.</p> <p>In the case of products from other firms, connect the device after studying the brochures of Data Logger and the sensor.</p>
Data Acquisition System	<p>Data Acquisition System means a system real-time process the data and express it by the engineering unit or trend graph during installation over some period at places where near-permanent measurement is required or the measurement is frequent. Installed are Pore Pressure Meter, Soil Pressure Meter, Tilt meter, and Load Cell on sites. The end of signal cable of each sensor is connected to Multiplex Module (or MUX, direct connection to a slew of signal cable is possible). Multiplex Module with Mail Controller (or Logger), accounting for communication network, controls Main Controller or P.C.</p> <p>For this operation, hard and software should be established including power part, operation software, protection cases, alarming system, and modems for wired and wireless communication, accessory for installation.</p> <p>Minimum Data Acquisition System can be comprised of power part, operation software, minimum Data Logger, Multiplex Module compatible with applied sensors according to site objectives or economic reasons.</p> <p>This chapter does not cover the connection and operation because of complicated nature. Refer to an additional brochure.</p>



[ACE-800]



[ACE-1000]



[ACE-1100]



[ADL-16V]



[ADL-200A]

4-1 Connecting Sensors with Readout unit

Use a jumper cable for connecting the sensor with VW data recorder (ACE-1000). Connect sensor socket with the end one side of the jumper cable, and connect sensor with the end other side. The jumper cable is easy to connect the sensor, because end of the jumper cable coupled alligator clips of four.

The method connect the signal cable of VW piezometer with the jumper cable is shown in the table below :

Division	Colors of signal cable	Colors of jump cable
Frequency	Red	Red
	Black	Black
Temperature	Green	Green
	White	White
Shielding	Silver-white	Silver-white

Connect with each other alligator clips of cable corresponds to the connection color of cable, as shown in the table when couple the signal cable of VW piezometer with the jumper cable of VW data recorder. Also, be sure to connect the shielding wire of jumper cable with the shielding wire of signal cable.

Frequency and temperature output line have nothing to polarity. There is no problem that each of 2 lines connects with swapped each other.

4-2 Connecting Sensors with Universal Terminal Box

Connect the output line of frequency with terminal block No.1, No.2. Connect the output line of temperature with No.3, No.4. Connect the shielding wire of cable with one out of No.5 or No.6. You must stick cable on the terminal block. And so, you must that the cable is not off or free by vibration or impact, when connect cable with the terminal block. Otherwise, lose the public confidence of measured value.

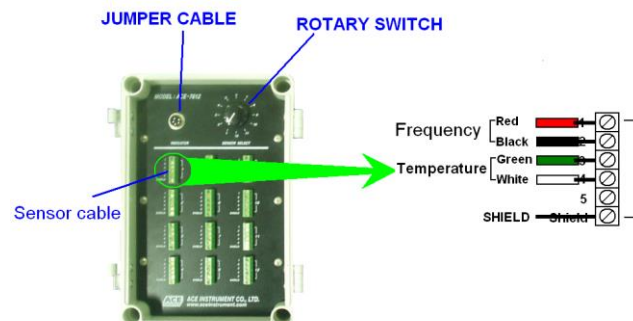

4-3 Reading with Readouts

Reading with VW readout unit (ACE-800)

- ① Connect Jumper Cable of VW Readout Unit to signal cable of VW piezometer. Connect the cable by referring the above 4-1 table about sensor connection of readout unit.
- ② Turn on the power of VW Readout Unit. Wait until LCD shows Sweep, displayed value and temperature of sensors for measurement.
- ③ When LCD shows Sweep, Display Mode and temperature, check whether the value is right. If frequency displayed value is shown as XXXX or blinking, check the Sweep, if it is not set within the range of **1.4-3.5 kHz**, reset the value by pushing MODE and SELECT buttons. Sweep falls into the range of 1,600~3,200 Hz.
- ④ Measure the Display Mode by choosing Frequency(Hz)
- ⑤ Record the values of Sweep and temperature.
(For further information on measurement, refer to the ACE-800 brochure.)

Reading with VW data logger
(ACE-1000)

- ① Turn on the power of VW Readout Unit. Wait until LCD shows Sweep, frequency and temperature of sensors for measurement.
- ② When LCD shows Sweep, Display Mode and temperature, check whether the value is right. If frequency value is shown as XXXX or blinking, check the Sweep, if it is not set within the range of **1.4-3.5 kHz**, reset the value by pushing MODE and SELECT buttons. Sweep falls into the range of 1,600~3,200 Hz.
- ③ Measure the Display Mode by choosing **Frequency(Hz)**.
- ④ Record the values of Sweep and temperature.
(For further information on measurement, refer to the ACE-1000 brochure.)

Caution

When VW piezometer is measured, initial value must be measured so that variation can be calculated by the engineering unit.

4-4 Reading with VW Mini Logger

Reading with VW mini logger
(ACE-1100)

- ① After opening the front cover of the VW Mini Logger with a driver, connect the end of signal cable of VW piezometer to ACE-1100. (The frequency input port and the temperature input port must be matched.)
- ② Insert the battery of the VW Mini Logger.
- ③ Connect the exclusive RS-232 Cable to teleport and then the serial port of PC.
- ④ Operate the instrument after implementing A1100Pro, the exclusive program and then adjusting setup and teleport.
- ⑤ By shortening the interval, check the temperature SWEEP and frequency of VW piezometer and then finish up the setting by setting the Interval as you please.
(For further information on measurement, refer to the ACE-1100 brochure.)

4-5 Reading with Wireless Data Acquisition System

Reading with smart logger
(ADL-200A)

- ① Connect the end of signal cable of VW piezometer to smart logger(ADL-200A).
(The frequency input port and the temperature input port must be matched.)
- ② Approve the power by using the exclusive adopter to smart loggers of ADL-200A.
- ③ Set the channel, frequency range (sweep) and temperature sensor type through the ADL 2Pro PC software of the ADL-200A.
- ④ Use the direct measurement option to check the frequency and temperature measurement values of the connected VW piezometer, set the measurement time (Interval) to the desired time, and finish the setting.
(For further information, refer to the ADL-200A brochure.)

Reading with VW data logger
(ADL-16V)

- ① Connect the end of signal cable of VW piezometer to VW data logger(ADL-16V).
(The frequency input port and the temperature input port must be matched.)
- ② Approve the power by using the exclusive adopter to VW data loggers of ADL-16V.
- ③ Set the channel, frequency range (sweep) and temperature sensor type through the ADL 16Pro PC software of the ADL-16V.
- ④ Use the direct measurement option to check the frequency and temperature measurement values of the connected VW piezometer, set the measurement time (Interval) to the desired time, and finish the setting.
(For further information, refer to the ADL-16V brochure.)

General information	VW piezometer is provided a calibration certification due to the nature of the product. Check the ABS Factor and Gage Factor to use. The information about the product, it is described in this manual. Please thoroughly read the information before using it.
ABC Factor & Gage Factor	<p>To improve the accuracy of the measurement data, it is used the ABC factory indicates the relationship between the output frequency and VW piezometer. ABS Factor is coefficient which is calculated relation with between the output frequency- piezometer as a quadratic function.</p> <p>The relation with VW piezometer's output frequency(Hz)-Pressure(kg/cm²) may indicate a straight line but, using this method, it can reduce the accuracy of measurement data. The VW piezometer's ABC Factor should be referred a calibration certificate for each sensor.</p>
Temperature coefficient	According changing temperature, the output frequency (Hz) is changed. When calculating corrected pressure, it must revise for this. The temperature coefficient means that the pressure change per 1°C. Therefore, by multiplying change amount of temperature in the temperature coefficient, the pressure due to the temperature change is calculated. Our company built a thermistor temperature sensor in product and then do temperatures test. The result is recorded on the calibration certification. The unit uses kg/cm ² /°C.
Corrected pressure(kg/cm ²) calculation	<p>The corrected pressure of VW piezometer can be calculated using a quadratic formula as follows:</p> <p style="text-align: center;">Corrected pressure(kg/cm²) = A x F² + B x F + C - T_{ct} x (T_c - T_i) - B_{cb} x (B_c - B_i)</p> <p style="margin-left: 40px;">F = Hz unit's measurement value A, B, C = Unknown of quadratic formula(refer calibration certification) T_{ct} = Temperature coefficient T_c, T_i = Current measured temperature, Initial measured temperature B_{cb} = Barometric pressure factor B_c = Current measured barometric pressure B_i = Initial measured barometric pressure</p> <p>Reference If measured by 10³Hz², please calculate as linear function by using gage factor which is recorded in the calibration certification.</p>
Correction for changes in barometric pressure	<p>The barometric pressure is recorded as mbar unit (barometric pressure at the time of calibration). This is a record of the exact measurement values by correcting the variation of the barometric pressure due to the height difference or the atmospheric environment. The barometric pressure is released from the weather station it does not exactly match the measurement time or location.</p> <p style="text-align: center;">Correction barometric pressure = (Barometric pressure at the time of measurement – Barometric pressure at the time of initial measurement) x Barometric pressure factor</p> <p>The Barometric pressure coefficient is a specific unit for the measurement of VW piezometer. The coefficient used for converting the barometric pressure varies as 10.215 x 10⁻³mH₂O per 1.0 mbar.</p>

Barometer Units	Convert units	Application factors
mbar	kPa	100 x 10 ⁻³
	kg/cm ²	1.0197 x 10 ⁻³
	Bar	1 x 10 ⁻³
	atm	0.9869 x 10 ⁻³
	mH ₂ O	10.215 x 10 ⁻³
mmHg	psi	0.01934
	mH ₂ O	0.01632

When measured value is unstable.

Measured value can become unstable when it is influenced by non-sensor parts or VW Readout Unit functions poorly. Check the following items.

- **Check whether any heavy equipment is in use around the measuring instrument.**
Electronic and electronic noises stemming from heavy equipment can be to blame. If heavy equipment is in use around the measuring instrument and this is to blame, grounding the Shield Wire of signal cable. During grounding, fix it firmly to metallic materials buried in the ground.
- **Check the voltage battery embedded in VW readout unit.**
Operate Mode Key of VW readout unit, allowing battery to be shown. Then the voltage of the cell is displayed. If the voltage of the cell is below 4.0V, recharging is needed.

When displayed as XXXX

Check below in the following order.

- **Check whether the Sweep Mode of VW readout unit is correctly chosen.**
If VW piezometer need to be used, check whether the Sweep Mode of VW readout unit is set within the range of 1.4 ~ 3.5 kHz.
- **Check whether Jumper Cable is connected or not.**
Check both ends of jumper cable by tester. Set resistance select button of multimeter and measured it. This time, if display "0Ω", cable is shorted. And if display infinity, cable is disconnected. Such a case, you must repair or change jumper cable.
- **Check if Signal Cable is shorted / disconnected.**
Check both ends of signal cable by tester. Set resistance select button of multimeter and measured it. This time, if display "0Ω", cable is shorted. And if display infinity, cable is disconnected. Such a case, you must repair or change signal cable.
- **Check the magnetic coil of VW piezometer.**
Set resistance select button of multimeter and check the gage. This time, if display "0Ω" or infinity, the gage is something wrong. Such a case, you must repair or change the VW piezometer.
When the resistance value of the frequency line is $240\Omega \pm 10\Omega$ it is state that VW piezometer is normally connected.
(Model 1500US is 66 ~ 70Ω)
- **Compare output frequency with the VW piezometer that is working to normal.**
You must repair or change the VW piezometer, when it is unable to measure output frequency by VW data recorder due to trouble of the VW piezometer on the inside.

Reference

A tester is a device which measures resistance, voltage, flow of electricity and frequency. Set Select Switch at proper numbers of resistance (Ω), voltage (V), flow of electricity (A)

When resistance is measured with a tester, set Select Switch at proper numbers of OHM and then connect Test Terminal to objects for measurement. After measuring resistance, if 0Ω is displayed, it means short-circuit. Or an infinity or OL is displayed, it means disconnection.

7-1 Keep/Care

Keeping products	<p>The VW piezometers are a precision gage with a built-in sensitive sensor. You must be keeping apart from another goods at place where is not get impact or vibration. And you must express caution by put on covers.</p> <p>You must be keeping at place where is well ventilate avoidable a direct ray of light. If expose to a direct ray of light for a long time, it is able to occur aged deterioration due to violent temperature change. Be cautions.</p>
Carrying products	<p>If VW piezometer gets impact or vibration in transit, the error may be increase because changed initial setting value. So, pay particular attention. Especially when wheeled, you must not put a heavy thing or get impact and must do immovably.</p>
Dealing with cable	<p>You must not bend cable. In case of install all sorts of instrument, you must express at the ends of cable in order that you may enable to divide each instrument.</p> <p>It is effectuality that connects cable to universal terminal box, when measuring. Also, this is method that you are able to handle the cable easily. Thus, we encourage this method.</p>
Checking measured value	<p>After measuring VW piezometer, check the change of measured value certainly. If fluctuation of measured values is very much, check for the trouble existence of sensor. And if there is not trouble in sensor, take action against that.</p>

7-2 Reform/Service

Reform	<p>When measured after a lapse of long time from shipping day, check for performance. For further information, please contact our company.</p> <p>After once only installing the VW piezometer, you are unable to correct and reuse it.</p>
Service	<p>Take Use and charge continually, after read enough and know well the instruction manual. If anything trouble happens in products, please let us know. We will check the trouble existence and performance.</p>

8. Simple test method for precision and accuracy

■ Simple test method for precision and accuracy

In order to prevent to use of improper and inadequate VW piezometer, you can check the accuracy of VW piezometer through actual tests at the office or field.

- ① Install the casing vertically by using the inclinometer casing at a height of about 10m from the site or the office of the building. It is better to use the inner diameter $\Phi 60\text{mm}$ or more if possible. Because the larger the inner diameter of the casing is much better. The casing must be connected by using ABS solvent for complete sealing.
- ② Fill the inside of the casing completely with water and record the height.
- ③ Check the initial value of the supplied VW piezometer and record the initial value against the calibration certificate. Return the product with a large initial value change because it is a defective product. Remove the filter part of the products to be tested and prepare a 10meter measure tape.
- ④ Use cable ties as shown in the figure to tie the tip of the piezometer. When inserting it into the inclinometer casing if the pore pressure gauge is facing downward, the residual air will not escape when encountering water. Straighten the signal cable and mark it on the cable in 1m increments base on where the diaphragm is located.
- ⑤ When you are ready, put the VW piezometer into the casing and lower it to the bottom. Note that the actual water head in the casing is the actual volume of the water in the casing, minus the water head of cable and the total volume of the VW piezometer, because the water in the full casing will overflow as much as the volume of the cable and piezometer body.
- ⑥ Wait about 20 minutes for the VW piezometer to fully reflect the water temperature, then lift it up by 1 meter and note the reading on the note.
- ⑦ By referring to the calibration certificate, it is a precise product when accuracy is less than 0.5% by comparing the value when it is lowered by 1m and actual test result.

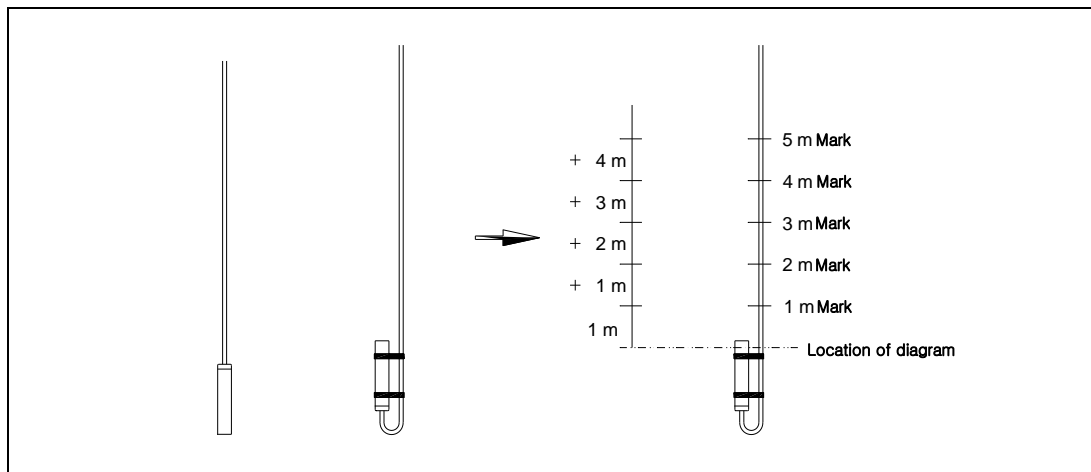

For example, calculation

- Calculation of the total volume inside the casing: Installation height 10m x inner diameter 60mm when using casing = 28.27
- Volume of VW piezometer + volume of signal cable = $0.036 + 0.33 = 0.366$
- The total volume of water in the actual casing = $28.27 - 0.366 = 27.904$

Because 0.366 of water overflowed for 10m, it corresponds to $0.336 = 13\text{mm}$.

Therefore, the actual water head will be $1000\text{mm} - 13\text{mm} = 987\text{mm}$ when VW piezometer is lowered by 1m.

The initial value is 2743.1Hz, A Factor : -0.000000320279

B Factor : -0.0033027265914

C Factor : 11.4682990416022 if the VW piezometer is lowered by 1m, theoretically, the pressure will be $987\text{mm} / 10 = 0.0987\text{kg/cm}^2$.

Actual pressure = $A \times F^2 + B \times F + C$ in the formula of

$$-0.000000320279 \times F^2 + -0.0033027265914 \times F + (-0.0033027265914) = 0.0987\text{kg/cm}^2$$

$$F = 2723.09z$$

Caution

When installing the VW piezometer, be sure to use a sealing kit by using Epoxy for the signal cable connection.

If taping is done just like connecting the signal cable of the measuring instrument of earth retaining in a humid place, moisture and water will penetrate into this place and it will eventually be short-circuited.

9. Geotechnical Instruments Installation and Operation Tips

1. Handling caution

Engineering measuring instrument is precisely manufactured and sensitive. Don't drop it and don't allow it to be exposed to external shocks. In particular, the VW measuring instrument is likely to see its zero point changed due to shocks.

2. Caution for storing calibration report

Calibration report is provided with each sensor. Information at the moment of calibration includes barometric pressure, calibration temperature, and temperature sensor in use, calibration data, conversion ratio and classification of signal cable by color. Therefore, you should be careful with storing the information until all work is done. In case the report is lost, tracking data and product might be impossible.

3. Operation by an engineer

All the process should be operated by a skilled engineer to prevent inappropriate choices such as errors of instrument choice, installation and operation which make impossible near-permanent calculation.

4. The need for shielding

It is common that sensor sends a weak electronic signal. And sensor is under the influence of electromagnetic induction, electrostatic induction static electricity electrification generated when other control machine is on. In particular, given that environmental condition of engineering work involving welding, generator, motor, antenna, and watery surface is poor, shielding and ground wire should be connected in the case of output device connection.

5. Caution for signal cable extension

There would be no problem that VW sensor outputting frequency signal is connected for extension. In the case that a sensor generating Voltage is connected for extension, electronic sensors are vulnerable to changes in resistance value. Therefore, the length of the cable plays a big influence. So, you should adjust resistance change value with adjustment value toward a sectional length of signal cable by manufacturers. Also, extension seam part should be finished up with Splice Kit (Epoxy).

6. The use of protection tube for signal cable

In the case of laying under the ground, dams, vulnerable foundation, concrete structures can have a big displacement, a source of signal cable disconnection. In the case of ground construction, given the construction condition, heavy equipment operation and frequent moving construction can be a source of disconnection or sensor damage. Therefore, caution should be taken for the protection of sensors and signal cables. And minimize the dangerous factors by using new construction pipe for drainage system.

7. Installation of Amplifier with sensors generating mV

Engineering measuring machine generating electronic signal has a 200-300 m transmission distance. In the case Junction Box and Terminal Box have a long distance from the measuring machine, an amplifier should be installed in proportion of measurement distance to prevent drop of voltage for sensor transmission.

8. Atmospheric pressure adjustment

When manometer is chosen as sensor, it is very sensitive to change in atmospheric pressure. Therefore, for precise measurement, places such as dams, valleys, the sea and reclaimed lands with high fluctuation of atmospheric pressure should adjust head height according to the difference of the pressure by using mercury barometer.

9. Lighting rod construction

In the case of large engineering work near water such as dams, lakes, the sea and large fields, valleys, lighting rods connecting each sensor individually should be constructed to protect sensors. Within the influence of over voltage, sensors are likely to function poorly.

10. Caution for filter use in pressure sensors

Pressure sensors such as negative pore water pressure have attached filters. Upon installation, make sure to let air out of the inside of the filter. Given that densities of air contraction and water are different, remained air might cause an error to measured value. Also, at places where unsaturated soil or negative pore water pressure are expected, it is recommended to use 1 μ m high-density ceramic filter.

11. Caution for bearing plate in use for load cell

For maintaining consistent measured value and high precision, the use of bearing plate is important, during installation of hard cell on Earth Anchor, heat processed steel materials should be manufactured with the enough thickness to endure unloading load and with the density of within 0.05 degree in top-down parallel lines. High quality products should be used for cone for spilt, cone-plate and mutual taper processed density.

12. Sensor temperature adjustment

An element of VW sensors uses wire rod (used for piano string) so that coefficient of linear expansion metallic materials hold can cause errors of margin and sensors of electricity and electron hold an adjustment factor. For precise measurement, adjust the difference of temperature with a mercury thermometer.

13. Auto Data Acquisition System requires UPS

In South Korea, relatively temporary blackout (0.5 seconds) is frequent. So overloading owing to simultaneous uses of equipment and accumulated power cables on sites are likely to cause ordinary and temporary blackouts, leading to computer Down and errors of built-in software. Therefore, When Auto Data Acquisition System is operated; UPS must be used to minimize dangerous factors.

14. Caution for the choice of VW output unit

manufactures of VW sensors and output units usually cover 600-3,200 Hz(= 360~10,240 10³Hz² or 1666~312 μ sec) for possible measurement range. And they design sensors taking into consideration the purpose of sensors, durability, and precision. Therefore, when Mode for unit choice of output unit within this range is changed, you must select sophisticated output unit making measurement possible.

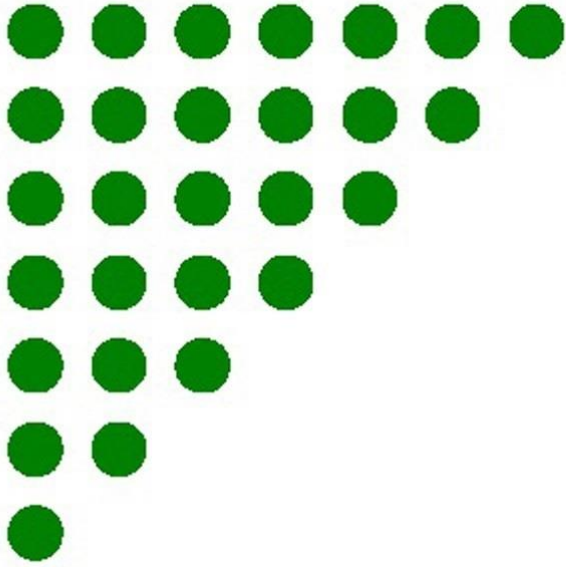

ACE INSTRUMENT CO., LTD.

The first value in Geotechnical
& Structural Instrumentation

Homepage : www.aceinstrument.com

E-mail : acens@naver.com